

HIGH-CURRENT SWITCH

DESCRIPTION

The 2N3724 is a silicon planar epitaxial transistor in TO-39 metal case. It is a high-current switch used for memory applications requiring breakdown voltages up to 30 V and operating currents to 1 A.

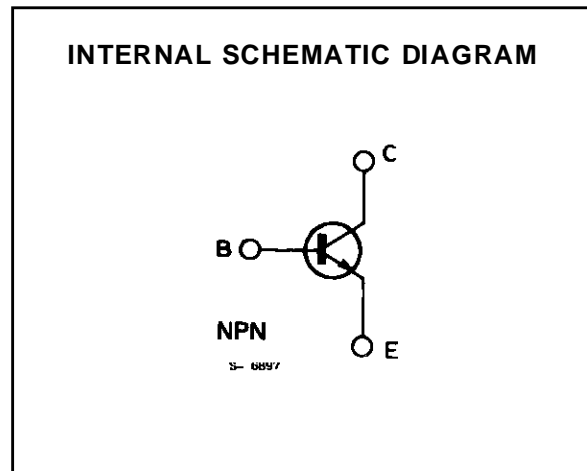
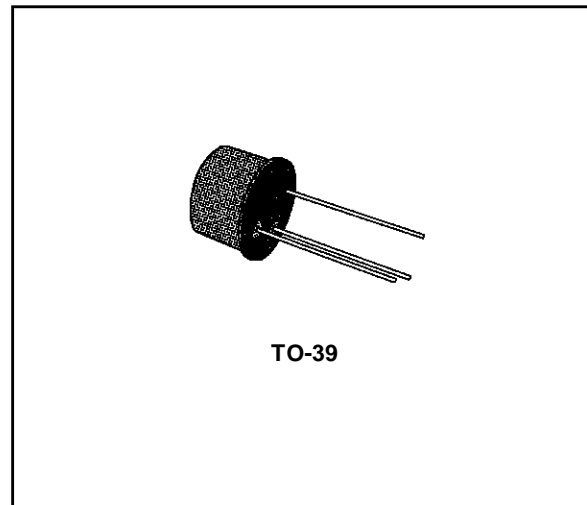

ABSOLUTE MAXIMUM RATINGS

Symbol	Parameter	Value	Unit
V_{CBO}	Collector-base Voltage ($I_E = 0$)	50	V
V_{CES}	Collector-emitter Voltage ($V_{BE} = 0$)	50	V
V_{CEO}	Collector-emitter Voltage ($I_B = 0$)	30	V
V_{EBO}	Emitter-base Voltage ($I_C = 0$)	6	V
I_C	Collector Current	1	A
P_{tot}	Total Power Dissipation at $T_{amb} \leq 25\text{ }^\circ\text{C}$ at $T_{case} \leq 25\text{ }^\circ\text{C}$	0.8	W
		3.5	W
T_{stg}, T_j	Storage and Junction Temperature	- 65 to 200	$^\circ\text{C}$

THERMAL DATA

$R_{th\ j-case}$	Thermal Resistance Junction-case	Max	50	$^{\circ}C/W$
$R_{th\ j-amb}$	Thermal Resistance Junction-ambient	Max	220	$^{\circ}C/W$

ELECTRICAL CHARACTERISTICS ($T_{amb} = 25\ ^{\circ}C$ unless otherwise specified)

Symbol	Parameter	Test Conditions	Min.	Typ.	Max.	Unit
I_{CBO}	Collector Cutoff Current ($I_E = 0$)	$V_{CB} = 40\ V$ $V_{CB} = 40\ V$ $T_{amb} = 100\ ^{\circ}C$			1.7 120	μA μA
$V_{(BR)CBO}$	Collector-base Breakdown Voltage ($I_E = 0$)	$I_C = 10\ \mu A$	50			V
$V_{(BR)CES}$	Collector-emitter Breakdown Voltage ($V_{BE} = 0$)	$I_C = 10\ \mu A$	50			V
$V_{(BR)CEO}^*$	Collector-emitter Breakdown Voltage ($I_B = 0$)	$I_C = 10\ mA$	30			V
$V_{(BR)EBO}$	Emitter-base Breakdown Voltage ($I_C = 0$)	$I_E = 10\ \mu A$	6			V
$V_{CE(sat)}^*$	Collector-emitter Saturation Voltage	$I_C = 10\ mA$ $I_B = 1\ mA$ $I_C = 100\ mA$ $I_B = 10\ mA$ $I_C = 300\ mA$ $I_B = 30\ mA$ $I_C = 500\ mA$ $I_B = 50\ mA$ $I_C = 800\ mA$ $I_B = 80\ mA$ $I_C = 1000\ mA$ $I_B = 100\ mA$			0.25 0.20 0.32 0.42 0.65 0.75	V V V V V V
$V_{BE(sat)}^*$	Base-emitter Saturation Voltage	$I_C = 10\ mA$ $I_B = 1\ mA$ $I_C = 100\ mA$ $I_B = 10\ mA$ $I_C = 300\ mA$ $I_B = 30\ mA$ $I_C = 500\ mA$ $I_B = 50\ mA$ $I_C = 800\ mA$ $I_B = 80\ mA$ $I_C = 1000\ mA$ $I_B = 100\ mA$	0.9	0.64 0.75 0.89 1.0 1.1	0.76 0.86 1.1 1.2 1.5 1.7	V V V V V V
h_{FE}^*	DC Current Gain	$I_C = 10\ mA$ $V_{CE} = 1\ V$ $I_C = 100\ mA$ $V_{CE} = 1\ V$ $I_C = 300\ mA$ $V_{CE} = 1\ V$ $I_C = 1000\ mA$ $V_{CE} = 5\ V$ $I_C = 800\ mA$ $V_{CE} = 2\ V$ $I_C = 500\ mA$ $V_{CE} = 1\ V$	30 60 40 30 25 35	60 90 60	150	
h_{fe}	High Frequency Current Gain	$I_C = 50\ mA$ $V_{CE} = 10\ V$ $f = 100\ MHz$	3			
C_{CBO}	Collector-base Capacitance	$I_C = 0$ $V_{CB} = 10\ V$ $f = 1\ MHz$			12	pF
C_{EBO}	Emitter-base Capacitance	$I_C = 0$ $V_{EB} = 0.5\ V$ $f = 1\ MHz$			55	pF
t_{on}^{**}	Turn-on Time	$I_C = 500\ mA$ $V_{CC} = 30\ V$ $I_B = 50\ mA$			35	ns
t_{off}^{**}	Turn off Time	$I_C = 500\ mA$ $V_{CC} = 30\ V$ $I_{B1} = - I_{B2} = 50\ mA$			60	ns

* Pulsed : pulse duration = 300 μs , duty cycle = 1 %.

** See test circuit.

Switching Characteristics.

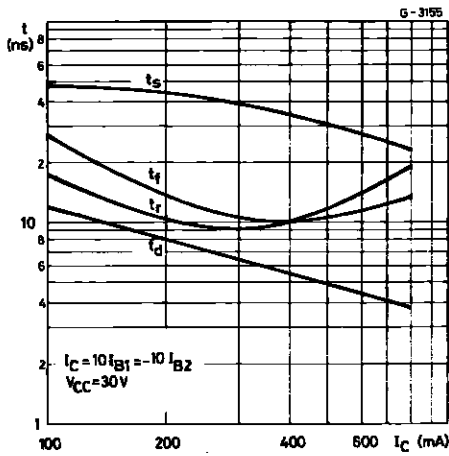

Switching Characteristics.

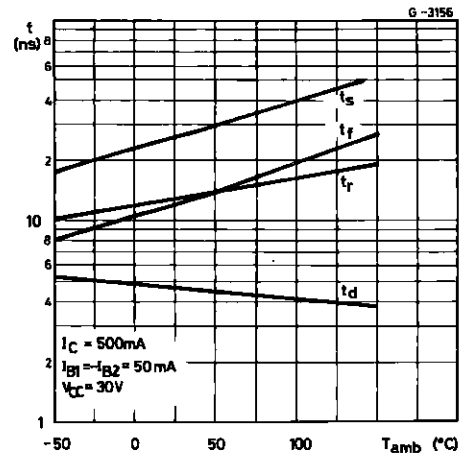

Test Circuit for t_{on} , t_{off} .

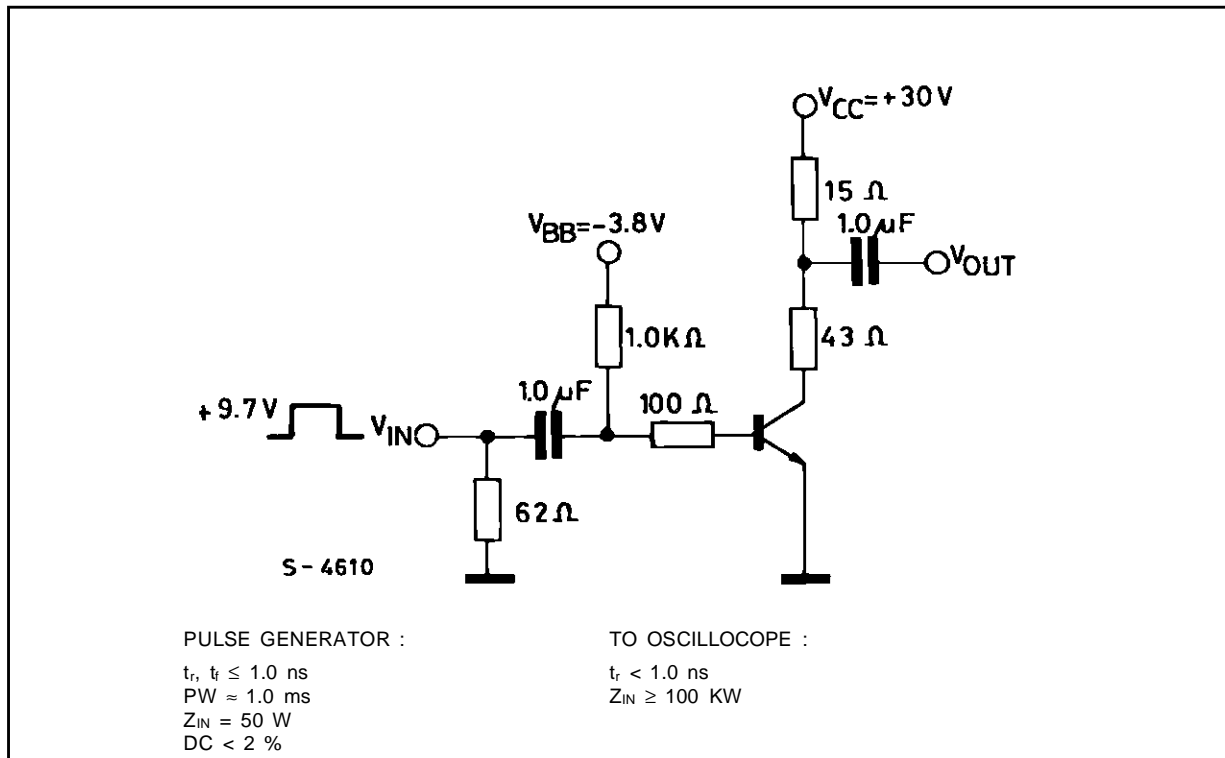

TO39 MECHANICAL DATA

DIM.	mm			inch		
	MIN.	TYP.	MAX.	MIN.	TYP.	MAX.
A	12.7			0.500		
B			0.49			0.019
D			6.6			0.260
E			8.5			0.334
F			9.4			0.370
G	5.08			0.200		
H			1.2			0.047
I			0.9			0.035
L	45° (typ.)					

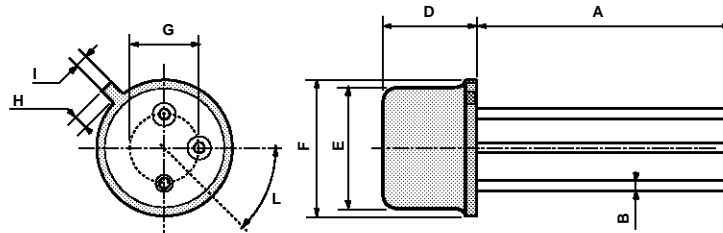

P008B

Information furnished is believed to be accurate and reliable. However, SGS-THOMSON Microelectronics assumes no responsibility for the consequences of use of such information nor for any infringement of patents or other rights of third parties which may result from its use. No license is granted by implication or otherwise under any patent or patent rights of SGS-THOMSON Microelectronics. Specifications mentioned in this publication are subject to change without notice. This publication supersedes and replaces all information previously supplied. SGS-THOMSON Microelectronics products are not authorized for use as critical components in life support devices or systems without express written approval of SGS-THOMSON Microelectronics.

© 1994 SGS-THOMSON Microelectronics - All Rights Reserved

SGS-THOMSON Microelectronics GROUP OF COMPANIES

Australia - Brazil - France - Germany - Hong Kong - Italy - Japan - Korea - Malaysia - Malta - Morocco - The Netherlands -
Singapore - Spain - Sweden - Switzerland - Taiwan - Thailand - United Kingdom - U.S.A